

Human Pedigree Analysis Problem Sheet

There are a number of different types of human pedigrees that you may encounter, however, there are only a few different modes of inheritance that you will need to be familiar. The following pedigrees show you different examples of human traits that can be traced through generations. See if you can identify the modes of inheritance, and answer any questions directly related to each pedigree. While you are working on this, keep the following clues in mind:

Clues for Autosomal Inheritance	
Recessive <ul style="list-style-type: none"> individual expressing trait has 2 normal parents two affected parents can not have an unaffected child 	Dominant <ul style="list-style-type: none"> every affected person has at least one affected parent each generation will have affected individuals
Clues for Sex-linked Inheritance	
Recessive <ul style="list-style-type: none"> no father-to-son transmission predominantly males affected trait may skip generations 	

1. For each of the pedigrees below, identify the mode of inheritance and provide at least 2 reasons for your choice.

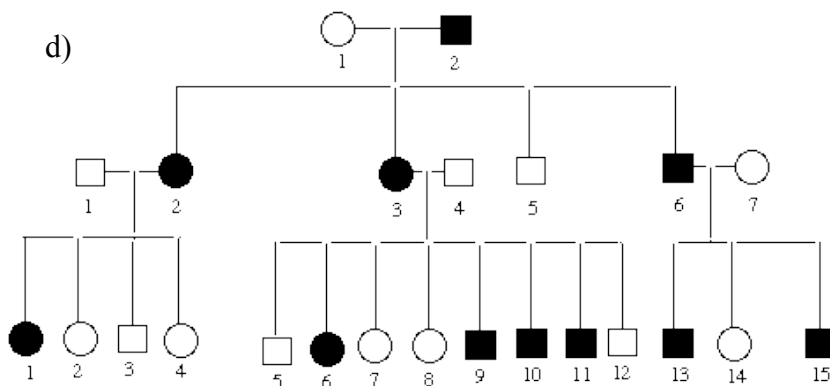
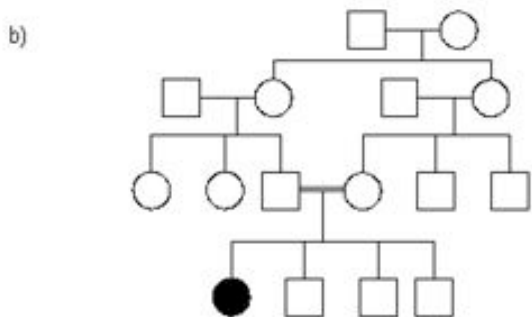
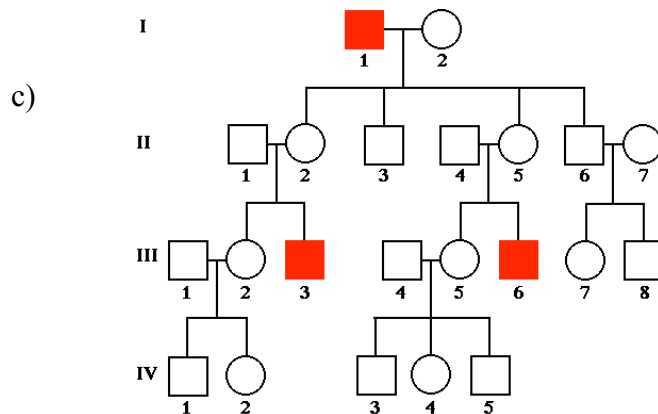
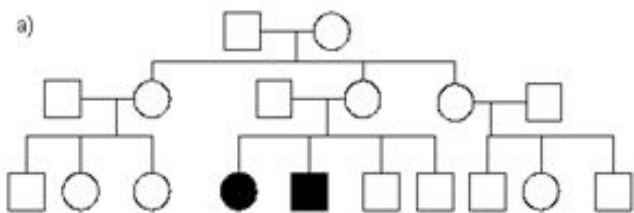

2. Below is a pedigree for an inherited lung disease. Provide the genotypes of each of the individuals marked with lower case letters.

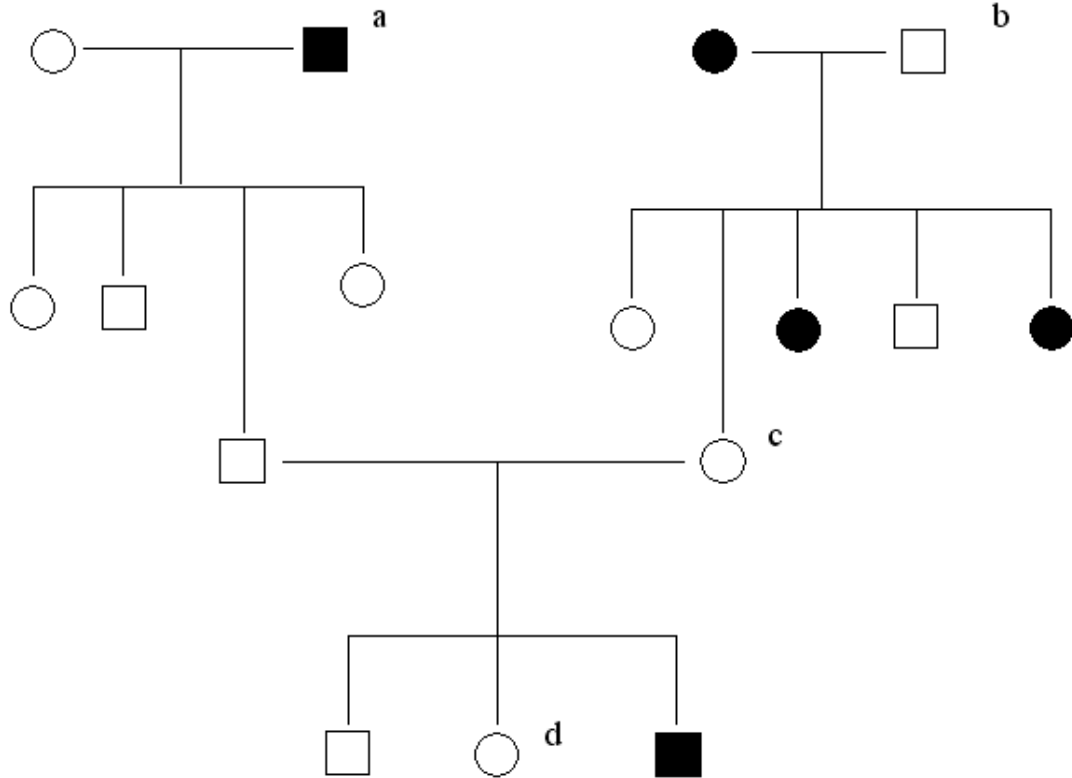

3. Below is a pedigree for an inherited brain disease. Provide the genotypes of each of the individuals marked with lower case letters.

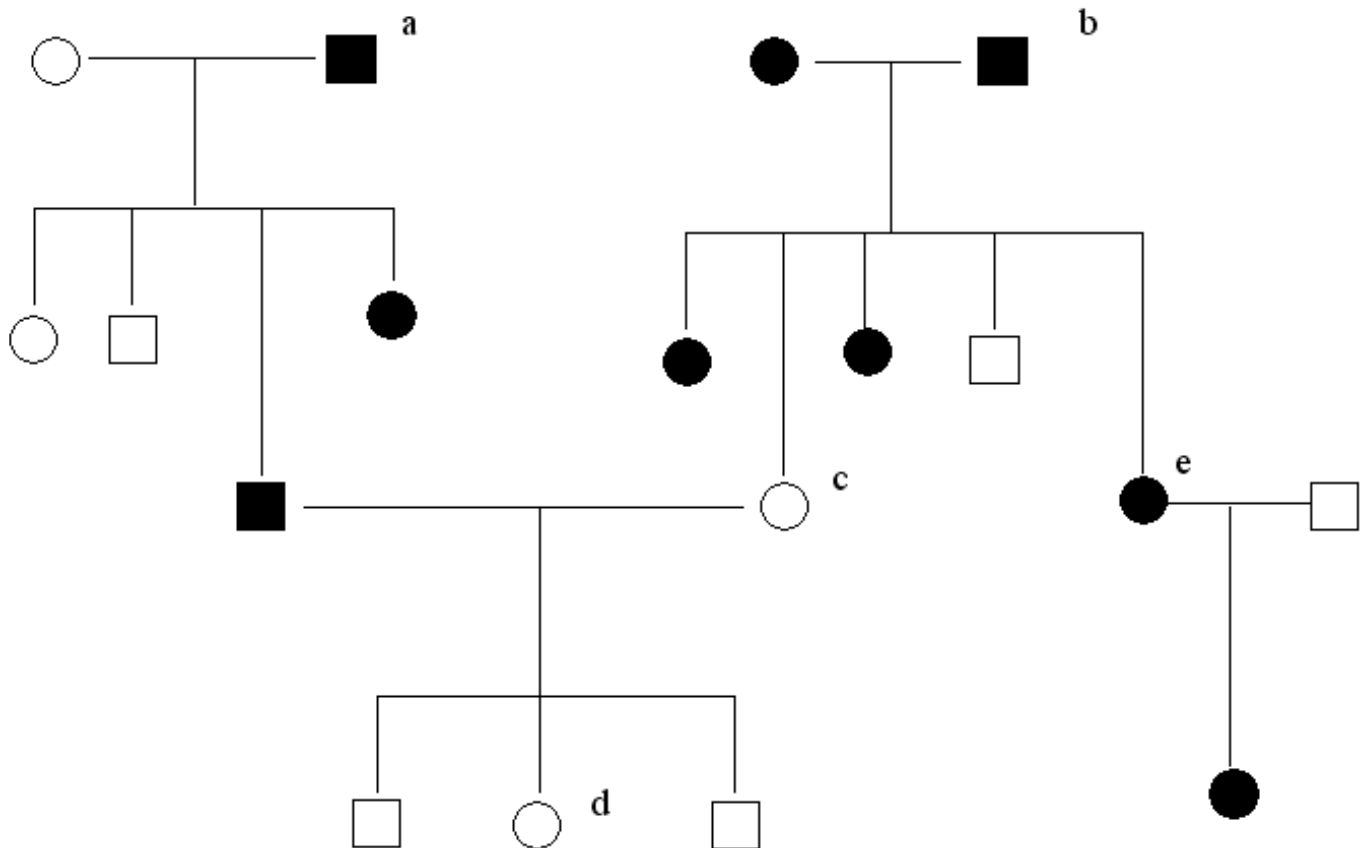

4. Use the Pedigree for Trait A to determine the genetic basis of this trait.

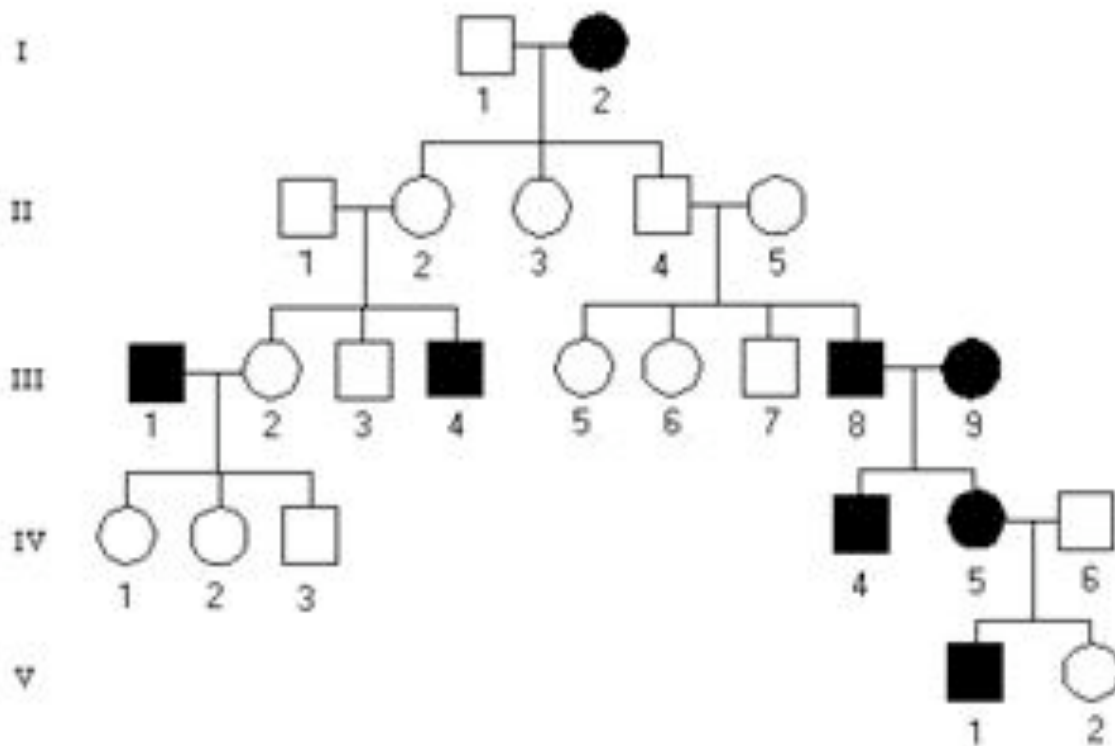

a. Does a dominant or recessive allele produce the trait? Explain.

b. Is it autosomal or sex-linked? Explain.

c. What are the genotypes of all the individuals in the pedigree? (Write them on the pedigree.)

d. What is the genotype of individual IV-2? Explain.

e. What is the genotype of individual IV-6? Explain.

f. What is the genotype of individual I-1? Explain.

5. Use the information provided below to create a pedigree. Then answer the question at

the end of each description.

- a. The ability to roll your tongue is dominant to not being able to roll your tongue. Draw a pedigree to show the inheritance of this trait, given the following family history:

Grandpa Snow is a tongue roller but Grandma Snow is not. They have four children (2 sons and 2 daughters) who are all rollers. Their last daughter, Judy, married John Flake. John's parents are both rollers, but John's two sisters are non-rollers. John is a roller. John and Judy Snow-Flake have three children named Crystal Snow-Flake (a non-roller), Pretty Snow-Flake (a roller) and Jake Snow-Flake (a roller).

- b. A man and woman marry. They have five children, 2 girls and 3 boys. The mother is a carrier of hemophilia, an X-linked disorder. She passes the gene on to two of the boys who died in childhood and one of the daughters is also a carrier. Both daughters marry men without hemophilia and have 3 children (2 boys and a girl). The carrier daughter has one son with hemophilia. One of the non-carrier daughter's sons marries a woman who is a carrier and they have twin daughters. What is the percent chance that each daughter will also be a carrier?
- c. The great-great maternal grandmother of a boy was a carrier for colour-blindness, an X-linked disorder. His great uncle on his mother's side was colourblind but his great uncle's father was unaffected. The boy's mother has 2 brothers (1 colourblind, 1 unaffected) and 1 sister (unaffected). The boy's grandmother on his mother's side had 1 brother who was colourblind and 3 sisters. Two of these sisters were unaffected and one was a carrier. The boy's great grandmother on his mother's side had 4 sisters. The boy has one unaffected sister and he is colourblind. What is the probability of the boy's sons being colourblind if he marries a non-carrier?